



SUBJECT: INSTALLATION OF NO-BACK CLUTCH SPRING P/N 203207-1 [MAC KIT #A10-85], IN AVIONICS PRODUCTS [EATON OR VICKERS] * LANDING GEAR ACTUATOR, P/N 102000 (X)

Revision C is prepared to revise Torque Values when a new No Back Clutch Spring is installed into the subject actuators.

MODELS/ S/N
AFFECTED: M20J, 24-0378 & ON **
M20K, 25-0001 & ON **
M20L, 26-0001 & ON **
M20M, 27-0001 & ON **
M20R, 29-0001 & ON **
M20S, 30-0001 & ON **

ALL AIRCRAFT WITH 940007-505 RETROFIT KIT INSTALLED.

- * OR SUBSEQUENT MANUFACTURER OF SAME PART NUMBER ACTUATOR WITH (X) BEING LATER DASH NUMBERS AS MANUFACTURER'S CHANGES ARE INCORPORATED.

** ALL S/N AIRCRAFT MAY NOT HAVE P/N 102000(X) ACTUATOR INSTALLED.

TIME OF COMPLIANCE: AT EACH 1000 HOUR INTERVAL OF AIRCRAFT OPERATION.

INTRODUCTION: To maintain high reliability of actuating system it is recommended that the no-back clutch spring be replaced every 1000 hours.

INSTRUCTIONS: 1. Remove the first two belly panels behind the nose wheelwell to gain access to actuator and bellcrank fittings. NOTE: Later aircraft have fiberglass belly skins and will require either the entire belly skin to be removed, M20J, M20K, or the forward piece to be removed, M20L, M20M, M20R to gain access.
2. Remove actuator from aircraft, disconnecting electrical connections, Heim bearing linkage and fuselage attach point bolt.
3. Remove the two (2) nuts, (Item 1) that retain the cable support bracket (Item 2); remove the bracket and disengage cable intact from actuator body and disengage arm.

DISASSEMBLY OF ACTUATOR:

4. To avoid stripping screw heads, use impact screwdriver to break Loctite thread seals and remove two (2) long screws (Item 3) and two (2) short screws (Item 4).
5. With razor or similar tool, slice through identification plate and remove recoiler assembly (Item 5) and Clutch Housing Mount Assembly (Item 5A).

NOTE: Care should be taken not to allow bearings to drop out of clutch housing mount assembly.

6. Remove input gear assembly (Item 6) from clutch housing (Item 8) by pulling with slight force.

7. Remove two (2) screws (Item 7) and remove clutch housing (Item 8), clutch (no-back) spring (Item 9), and output gear assembly (Item 10) from actuator body.

8. Remove clutch (no-back) spring (Item 9) from clutch housing using input gear assembly (Item 6) as removal tool. Insert Item 6 into clutch spring from flanged end of housing (Item 8), and remove clutch (no-back) spring by rotating gear CCW and pulling slightly.

NOTE: DO NOT TURN CW. Spring can be damaged.

INSTRUCTIONS:
(con't.)

GENERAL:

After disassembly, clean clutch, gears, and housing thoroughly. Discard screws (Item 3 & Item 4). Fill out tag with information requested. Discard old clutch (no-back) spring.

REASSEMBLY:

1. Lubricate clutch housing and new spring with lubricant supplied.
2. Using gear assembly (Item 6) as insertion tool, place new clutch spring on cam end of assembly and turning CCW, install spring into clutch housing to about mid-point. Do not force spring. While turning CCW, gently push into housing.
3. Withdraw gear assembly (Item 6).
4. Insert clutch gear assembly (Item 10) into clutch spring and housing from cylindrical end of housing, insuring that clutch spring tangs fit into recesses in cam.

NOTE: When clutch spring is properly seated, large gear (Item 6) can be rotated in either direction and small output gear (Item 10) will follow rotation direction.

5. Lubricate output gear teeth (Item 10) (lubricant supplied in kit) and install clutch housing, gear and spring assembly into actuator body by mating (Item 10) gear to the output gear train assembly. To engage gear teeth and fully seat hub into bearing, rotation of gear assembly may be required.

6. Re-install screws (Item 7) to secure clutch housing into actuator body. Use Loctite Grade A on threads.

7. Re-insert input gear assembly (Item 6) into clutch housing and clutch spring assembly until fully seated. Lubricate (Item 6) gear teeth with lubricant supplied in kit.

NOTE: Clutch assembly can now be verified for proper installation by rotating input gear (Item 6) both CW & CCW. Gears should turn with moderate friction to hand torque. Observe that output screw jack rotates in both directions.

NOTE: In some instances, the new clutch (no-back) spring chatters during electrical extension or retraction cycle. Proper shimming of the no-back clutch housing assembly, (Items 6, 7, 8, 9 & 10), and bearing (Item 11) with shims (Item 12) is necessary according to Eaton personnel to eliminate the chatter.

8. Disassemble Clutch Housing Mount Assy., (Item 5A) from Recoiler Assembly (Item 5). **Do not allow bearings or shims to drop out of clutch housing mount assembly.**

9. Normally, the existing shims (Item 12) already installed behind bearing (Item 11) will be correct for the new clutch spring. However, due to manufacturing tolerances, it may be necessary to change shim thickness for proper spring adjustment.

10. Three different thickness of shims are available through MAC Service Centers: EATON P/N 110117-1 (.003 in. Thk), 110117-2 (.005 in. Thk), & 110117-3 (.010 in. Thk). Any combination of these shim thickness are allowed to obtain correct rotational torque (inch pounds of torque) of input gear shaft after clutch housing mount assembly is installed and torqued.

11. Install housing mount assembly (Item 5A). Tighten housing screws. Check rotational torque of the no-back clutch drive with a modified socket & torque wrench. Rotational torque should be 4 inch pounds in both directions. The objective is to remove endplay without applying a preload on the bearings.

If rotational torque is greater than 4 inch pounds, remove housing mount (Item 5A) and remove the least amount of shims (Item 12) necessary to obtain proper rotational torque.

12. When the correct rotational torque has been obtained, reinstall recoiler assembly (Item 5).

NOTE: Flats on (Item 6) gear shaft must line up with Brass manual drive clutch for proper assembly. Pull manual drive cable slightly to position Brass clutch to align with flats on gear shaft (Item 6).

13. Install four (4) new bolts (Item 3 [ADS145-10-43] & Item 4 [ADS145-10-38]) supplied in kit and torque bolts to 20 - 25 inch pounds.

14. Re-install cable support bracket and lock nuts on -43 bolts. Torque lock nuts to 20 - 25 inch pounds.

INSTRUCTIONS:
 (con't.)

15. Install modification plate as shown (at first 1000 hrs. only). Mark the first block of modification plate with the figure "1" using metal stamp or etching tool. Mark each succeeding clutch spring re-placement with the next consecutive number.

16. Re-install actuator in aircraft and verify rigging per Service and Maintenance Manuals, M20J, No. 106, SECTION 5-6A and M20K, No. 231, SECTION 5-7; M20L, M20M, M20R, & M20S, and in later M20J & M20K S & M manuals, SECTION 32-30-02). Caution should be observed during installation for placement of washers and bushings.

17. Re-install belly panels.

18. Enter compliance note in aircraft log book and return aircraft to service.

WARRANTY:

REFERENCE
 DATA:

N/A

PARTS LIST:

Kit P/N	--	SI 20-52-001	(A10-85 – OLD EATON P/N) Clutch Spring Kit
<u>Item</u>		<u>Part Number</u>	<u>Description</u>
1.		203207-1	SPRING, CLUTCH (NO-BACK) 1
2.		102052	MAINTENANCE RECORD METALCAL 1
		102049	DATA PLATE (ALTERNATE FROM EATON)
3.		MIL-G-81322	GREASE (POLY-LUBE) 1
4.		ADS145-10-43	BOLT 2
5.		ADS145-10-38	BOLT 2
6.		MS20365-1032	LOCKNUT 4 ***

*** Only 2 MS20365-1032 LOCKNUTS are required when using two ADS145-10-38 BOLTS. Older version of kit contained four ADS145-10-43 BOLTS for all four locations.

TOOLS
 REQUIRED: 3/8" WRENCH
 SCREWDRIVER, COMMON
 MACHINIST HAMMER
 K-D1141 IMPACT SCREWDRIVER or EQUIVALENT ****
 TORQUE DRIVER, ¼ INCH DRIVE, 0 TO 15 (APPROXIMATELY) INCH
 POUNDS (SPECIAL MADE "SOCKET" TO FIT TORQUE DRIVER AND
 FLATS ON INPUT GEAR SHAFT (ITEM 6).

**** KD TOOLS, Lancaster, PA. 17604

EATON CORPORATION, EL SEGUNDO, CA – TELEPHONE: (310) 725-3050

FIGURE/TABLES: SEE ILLUSTRATION ON FOLLOWING PAGE

FIGURES/
TABLES: (con't.)

FIGURE SI M20-52-1

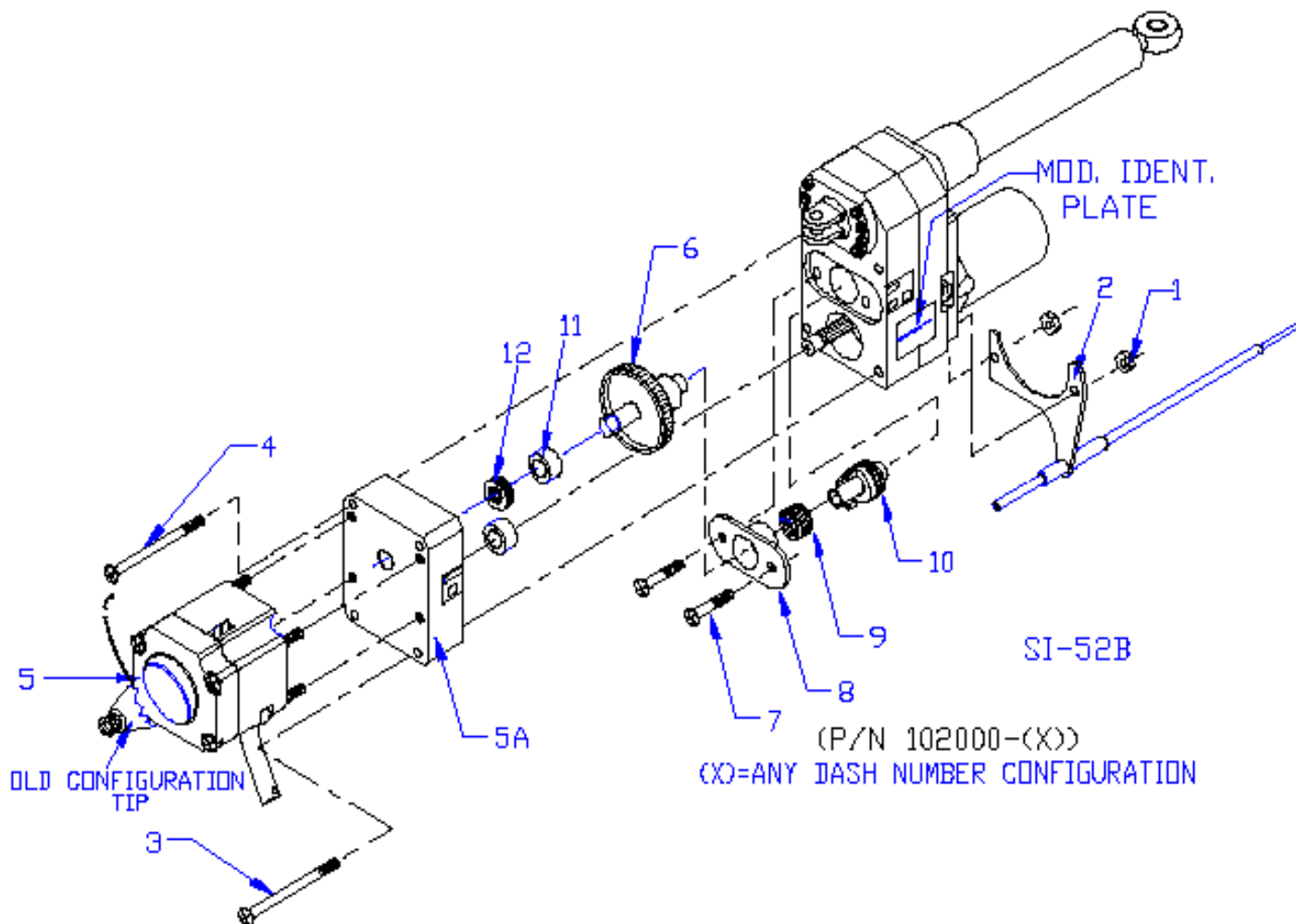

FIGURE SI M20-52-1