



S.I. Number: M20-35
Date: 1-15-76

SERVICE INSTRUCTION

- SUBJECT:** Inspection of Empennage Attach Brackets
- MODELS AFFECTED:** All M20 Series aircraft equipped with metal tails manufactured prior to November 1, 1975.
- TIME OF COMPLIANCE:** Within the next 100 hours.
- INTRODUCTION:** Evidence has been found that an accumulation of assembly tolerances may result in decreased rigidity of the empennage at the attachment to the tailcone. Since this condition is likely to exist in all M20 Series airplanes equipped with all metal tails it is necessary that the following inspection and corrective action be performed.
- PROCEDURE:**
- 1) Remove 470002-7 and -8 fairings (Figure 1).
 - 2) Check torque on the AN 174-20A bolt (Figure 2) 60-70 IN-LBS. dry threads. (Due to the inaccessibility of the nut the torque must be checked on the bolt and consideration must be given to friction in accordance with AC 43-13 Chapter 5, Section 227.)
 - 3) Using a .005 feeler gage check between the 350060 bracket and the 350055 fitting (Figure 2). If feeler gage touches shank of bolt continue with Step 4. If gap does not exist no rework is required.
 - 4) Support the empennage and remove the bolt carefully noting the arrangement of washers used as spacers. These must be replaced in the reverse order of removal.
 - 5) Shim as required to eliminate gap between the 350060 bracket and the 350055 fitting with aluminum shim stock in the shape of an AN 960-416 washer. "Do not use brass shim stock". (Maximum allowable gap with bolts loose and shims installed is .019").
 - 6) Carefully inspect the condition of the AN 174-20A bolt. Replace if any signs of wear are evident. Reinstall the AN 174-20A bolt, washers, and AN 365-428 nut in the reverse order of disassembly. Torque to 60-70 IN-LBS. (dry thread) and again check gap between the 350055 fitting and the 350060 bracket.
 - 7) Install 470002-7 and -8 fairings (Figure 1).



S.I. Number: M20-35
Date: 1-15-76

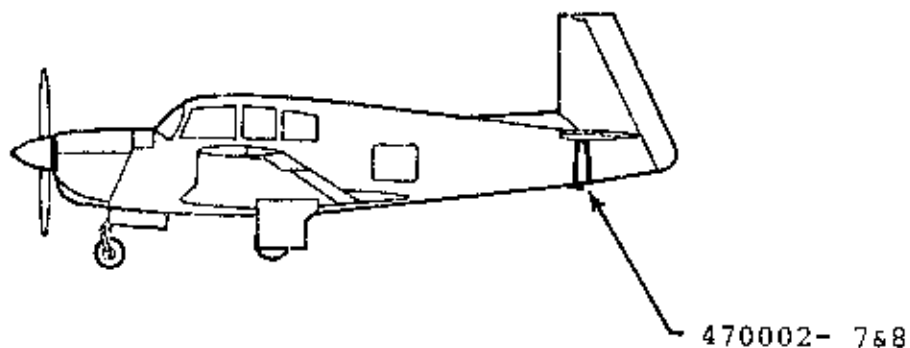

FIGURE 1

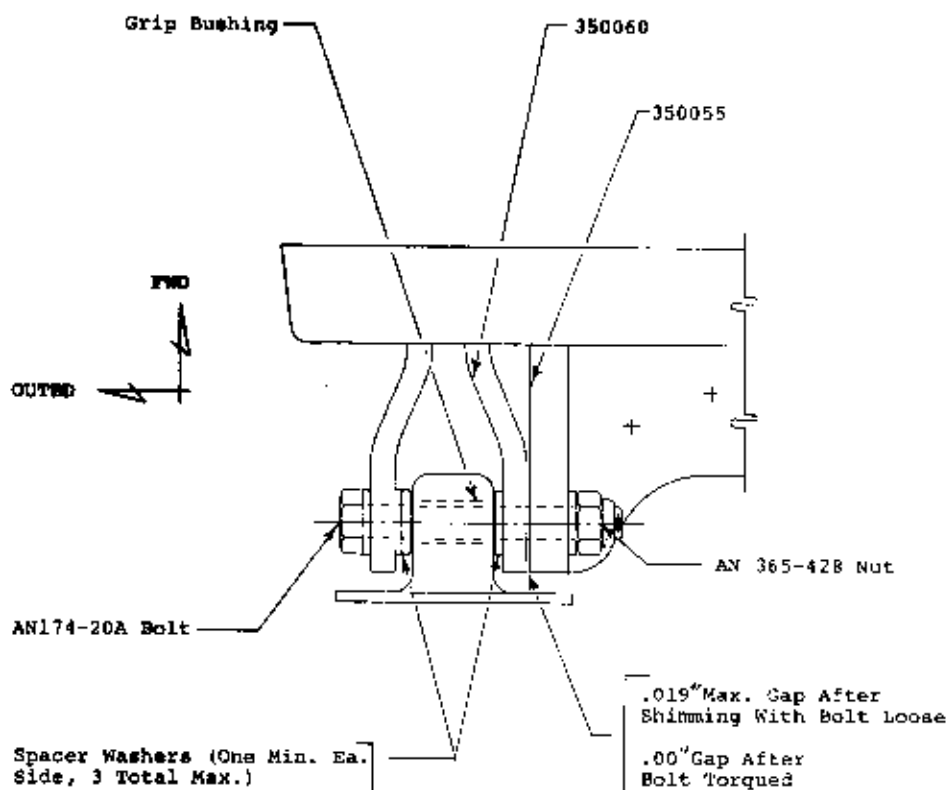

FIGURE 2 (View Looking Up)