



SUBJECT: SEAT BACK CUSHION MODIFICATION

**MODELS/ SN
AFFECTED:** M20U OVATION ULTRA 32-0001 AND 32-0002
M20V ACCLAIM ULTRA 33-0001 THRU 33-0006

**TIME OF
COMPLIANCE:** AS REQUIRED

INTRODUCTION: Mooney International Corporation has determined the need to trim the front seat back cushions to allow clearance between bottom cushion and seat height adjustment handle. This service instruction provides the procedure for removing seat foam and trimming for better fitment.

Procedure for trimming seat back foam.

- 1.1. Remove both Pilot and Co-Pilot seat assemblies by removing MS27039-0818 Screws, MS21042-8 Nuts and 140188-001 Bushings and 140339-001 Seat Stops (bag and identify bushings for reassembly) forward and aft; push seat forward to lift up front of seat structure, then aft to lift up rear rollers of seat structure, as shown in Figure SB M20-127-1. Installation is the reverse of removal.

NOTE:

For Aircraft equipped with Optional Amsafe Inflatable Restraints, refer to the specific Mooney Service and Maintenance Manual for removal and installation procedures.

- 1.2. Remove bottom seat cushion, by lifting and separating the Velcro strips from cushion and bottom seat base.
- 1.3. Remove (2 qty) AN23-14A Screws, (2 qty) NAS1149F0363P Washers and (2 qty) MS21042-3 Nuts mounting seat back frame to bottom seat frame assembly (bag and identify hardware for reassembly), as shown in Figure SB M20-127-1.
- 1.4. Carefully, lift and remove seat back assembly from bottom seat assembly and move to clean work bench.
- 1.5. Carefully, separate leather glued too frame, exposing seat back cushion as shown in Figure SB M20-127-2. If Leather is pulled too fast from glued frame, tearing or distortion could occur.

CAUTION:

Carefully separate leather from frame area to expose lower seat back foam. The leather is glued in place with #1357 3M adhesive.

- 1.6. With a long knife blade, trim bottom of seat cushion as shown in Figure SB M20-127-2.
- 1.7. Glue leather to frame with #1357 3M adhesive, cover seat back cushion as shown in Figure SB M20-127-2. Allow glue to dry per manufactures instructions.
- 1.8. Carefully install seat back into place with (2 qty) AN23-14A Screws, (2 qty) NAS1149F0363P Washers and (2 qty) MS21042-3 Nuts mounting seat back frame to bottom seat frame assembly, as shown in Figure SB M20-127-1.



- 1.9. Install bottom seat cushion, by tucking rear of cushion under seat back, pushing down will allow Velcro strips to connect with each other. Make sure seat cushion is tucked far enough to allow seat height adjustment lever to clear front of seat cushion.
- 1.10. Install both Pilot and Co-Pilot seat assemblies by inserting bottom of seat rail into floorboard seat rail slots and install MS27039-0818 Screws, MS21042-8 Nuts and 140188-001 Bushings and 140339-001 Seat Stops, as shown in Figure SB M20-127-1.

NOTE:

For Aircraft equipped with Optional Amsafe Inflatable Restraints, refer to the specific Mooney Service and Maintenance Manual for removal and installation procedures.

NOTE:

Fill out compliance card and send by MAIL, FAX or EMAIL to Mooney International Corporation as indicated on the attached Compliance Card (see to Figure M20-127-3).

WARRANTY: Mooney International Corporation will warrant labor 6 hours when work is completed in accordance with procedures of this Service Instruction for aircraft currently covered under the Mooney International Corporation factory warranty program.

REFERENCE DATA:

1. Applicable Mooney International Service and Maintenance Manual
2. All work to be performed by a current FAA Certified Mechanic
3. For technical assistance email support@mooney.com

PARTS LIST: N/A

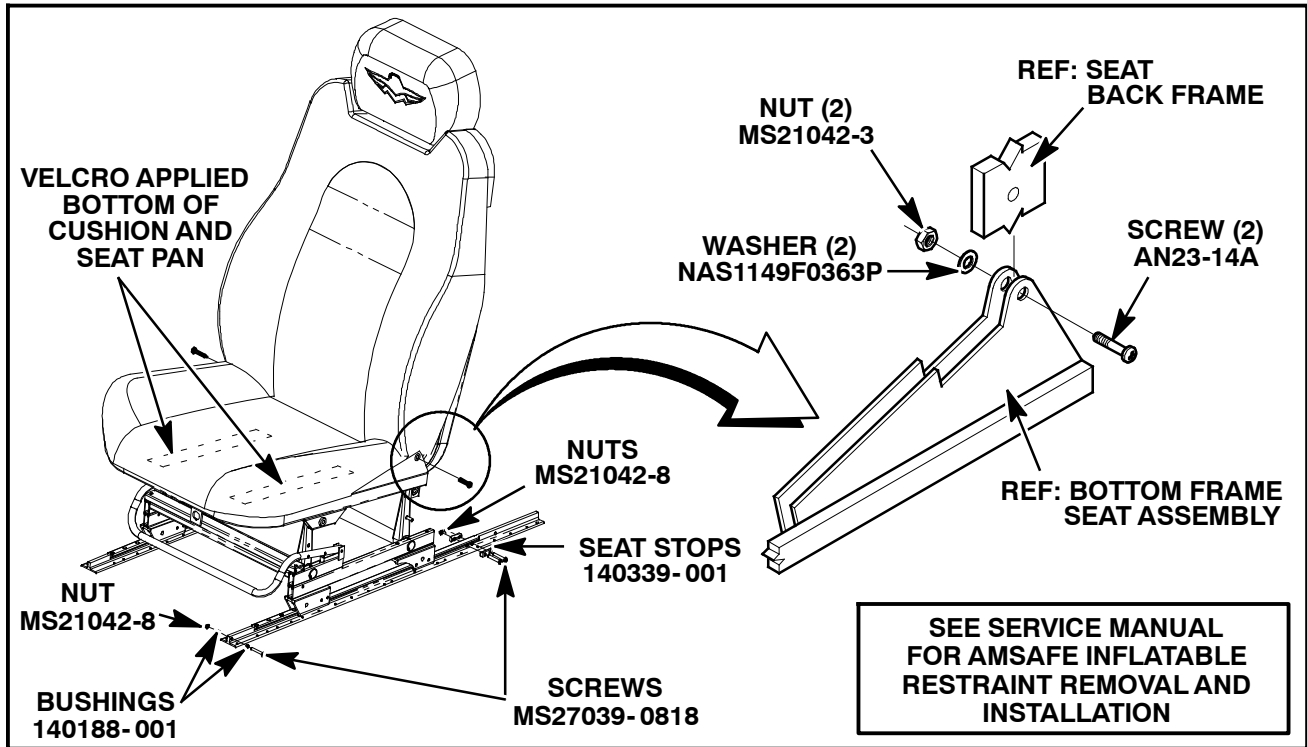

Figure SB M20-127-1 - REMOVAL OF SEATS AND SEAT BACK ASSEMBLY

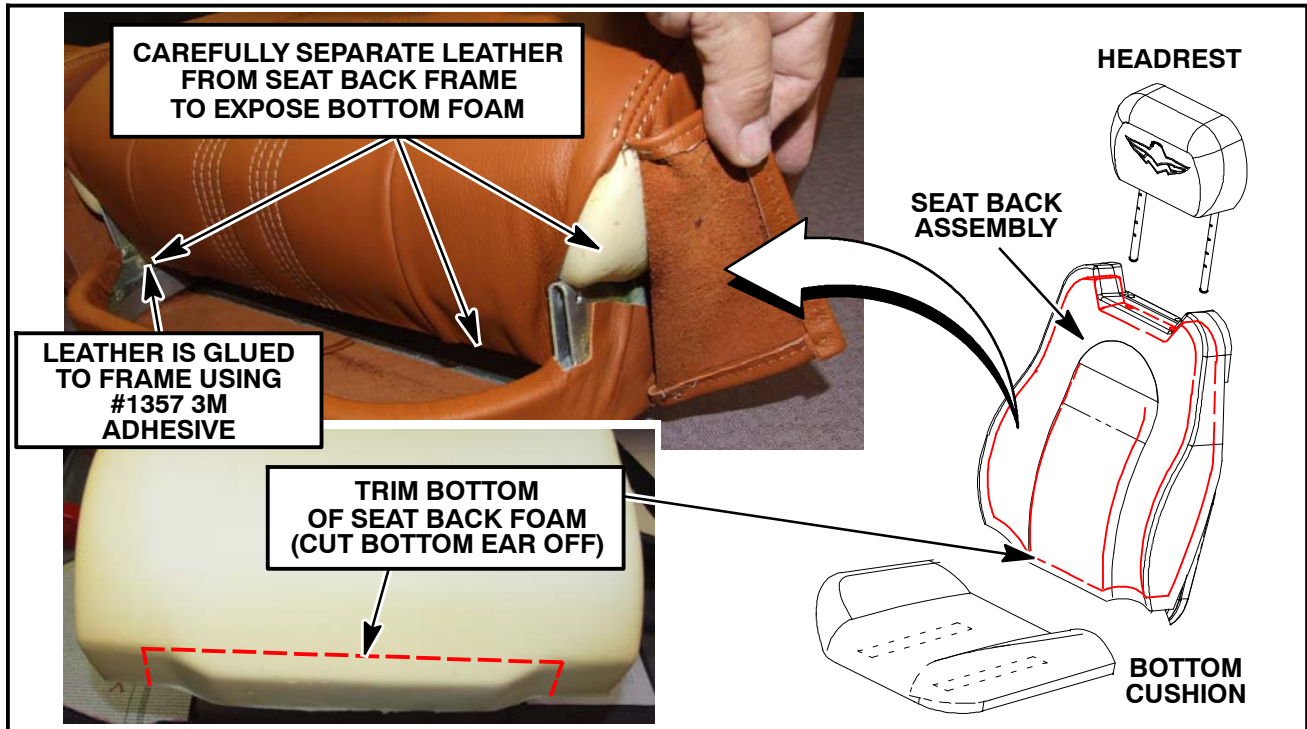

Figure SB M20-127-2 - SEPARATE SEAT BACK LEATHER AND TRIM FOAM AS REQUIRED



MOONEY INTERNATIONAL CORPORATION
KERRVILLE, TEXAS 78028 - FAX 830-257-4635

SERVICE (BULLETIN) (INSTRUCTION) NO. _____ HAS BEEN COMPLIED
WITH ON AIRCRAFT MODEL _____ SERIAL NUMBER _____

Tach. Time: _____ N-Number _____ (Reg. No.)
Owner: _____ Date of Compliance: _____
_____ Complied By: _____

Inspection Report: _____

Form 07-0001

PLACE
STAMP
HERE

MOONEY INTERNATIONAL CORPORATION
ATT'N: TECHNICAL PUBLICATIONS DEPT
165 Al Mooney Road, North
Kerrville, Texas 78028

SEND TO: Mooney International Corporation
165 Al Mooney Road North
Kerrville, TX 78028
FAX: (830) 257-4635 or EMAIL TO: techpubs@mooney.com

Figure SB M20-127-3 - FILL OUT COMPLIANCE CARD