

SUBJECT: Mooney M20M, Retrofit, cabin exhaust vents on fuselage sides/cabin ventilation system modification.

MODELS/S/N

AFFECTED: PART 1: M20M - S/N 27-0002 THRU 27-0137 (EXCEPT S/N 27-0094)
PART 2: M20M - S/N 27-0053 THRU 27-0167 (EXCEPT S/N 27-0094)
PART 3: M20M - S/N 27-0002 THRU 27-0052

TIME OF

COMPLIANCE: Within next 25 flight hours or at next scheduled maintenance action.

INTRODUCTION: In order to provide a continual purge of the cabin air, compliance of this Service Bulletin needs to be accomplished for serial numbers listed above.

INSTRUCTIONS:

PART 1: ADD CABIN EXHAUST VENTS (FIG. SB M20-255-1)
(S/N 27-0002 thru 27-0167, excluding S/N 27-0094)

1. It is recommended, but not essential, to remove aft interior baggage compartment ABS panels, both sides. The long ABS panels, forward of the baggage compartment panels, will need to be pulled UP and restrained UP to provide access to the inside skin. These long ABS panels may be removed, if desired, to accomplish the retrofit.

Caution should be observed during cut out of hole and drilling of rivet holes in fuselage skin so as not to drill through any electrical wiring, ABS panels or tubular structure.

2. Locate area of fuselage skin to be cut out by measuring from the baggage compartment/cabin area, vertical skin lap, forward, 9.0 inches and down 16.4 inches from lower edge of aft window skin cut-out. The size of each cut-out should be 2.9 inches high and 2.26 inches wide. Keep vertical sides of cut-out parallel with vertical skin lap. Recommended radius on all corners of cut-out is .125 inches. (Fig. SB M20-255-1)
3. Deburr cut-out.
4. Cleco 640296-001 ABS baffle to a louvered plate for L/H side sub-assembly to verify that all pilot holes in baffle and louvered plate are matched. Drill all pilot holes out to #30 holes. Repeat for R/H side sub-assembly. Identify louvered plates as R/H and L/H during this procedure.
- NOTE: - Be sure that louvers will have openings toward the aft end of the aircraft.**
5. After drilling #30 matching holes in baffle and louvered plate, sandwich a 640247-003, aluminum screen between L/H baffle and L/H louvered plate; punch matching holes through screen mesh with an awl. Repeat for R/H side sub-assembly.
6. Place R/H 640130-000 louvered plate in position, over R/H cut-out hole, in accordance with Fig. SB M20-255-1. The location of the louvered plate does not have to be exact, however, a minimum of .31 inches edge distance should be maintained for all fasteners. Drill #30 holes in fuselage skin to match #30 holes in louvered plates (13 places for each plate). Reference Fig. SB M20-255-1. Repeat for L/H cut-out hole.
7. Install R/H louvered plate (outside of fuselage skin), R/H aluminum screen and 640296-002 ABS baffle (inside of fuselage skin) with Avex 1691-0410-05 rivets and AN960-6 washers. Sandwich aluminum screen between ABS baffle and inside surface of fuselage skin as shown in Fig. SB M20-255-1. Repeat for L/H side.
8. Clean up area and install ABS interior panels, if removed.
9. Paint rivets, attaching louvered plates, to match exterior paint color.
10. Enter compliance note in log book and return aircraft to service.
11. Fill out and return pre-addressed, stamped compliance card.

PART 2: REPLACE BUTTERFLY ASSEMBLY IN CABIN VENTILATION J-BOX (FIG. SB M20-255-2)
(S/N 27-0053 THRU 27-0167, excluding S/N 27-0094)

1. Locate cabin ventilation J-Box in forward, RH cabin immediately behind firewall.
2. Access J-Box assembly by loosening QS100-M40S clamp at J-Box and flex tubing connection; replace existing 640326-505 butterfly assembly with new 640326-511 butterfly assembly, Fig. SB M20-255-2.
3. Re-install flex tubing to J-Box with QS100-M40S clamp.
4. Enter compliance note in log book and return aircraft to service.
5. Fill out and return pre-addressed, stamped compliance card.

PART 3: MODIFICATION OF SLIDE PLATE ON CABIN VENTILATION J-BOX. (FIG. SB M20-255-3)
 (S/N 27-0002 THRU 27-0052)

1. Locate cabin ventilation J-Box in forward, RH cabin immediately behind firewall.
2. Access J-Box slide plate assembly by loosening QS100-M40S clamp on J-Box **outlet air flex tubing** connection. Use needle nose pliers to remove MS16562-4 roll pin from slide plate. Remove cable assembly/cable stops from slide plate. Remove existing 640010-000 slide plate from J-Box.
3. Modify 640010-000 slide plate by drilling two 0.50 inch diameter holes, in locations as shown in FIG. SB M20-255-3. Slide Plate must now be re-identified as P/N SB M20-255-501; use indelible ink to mark P/N on body of slide plate.
4. Re-install modified slide plate into J-Box assembly. Attach cable assembly with existing cable stops and hardware.
5. Position slide plate so MS16562-4 roll pin can be inserted into hole through outlet air flex tube opening.
6. Verify slide plate operation is smooth and complete travel can be obtained in both directions, prior to installation of flex tubing.
7. Re-install flex tubing to J-Box with QS100-M40S clamp.
8. Enter compliance note in log book and return aircraft to service.
9. Fill out and return pre-addressed, stamped compliance card.

Applicable kits should be ordered from Mooney Service Centers.

WARRANTY:

Mooney Aircraft Corporation will allow 4.0 hours labor to incorporate applicable portions of this Service Bulletin on A/C S/N's 27-0002 THRU 27-0137 and 1.0 hours labor on A/C S/N's 27-0138 THRU 27-0167 if compliance card and warranty paper work is received from Service Center by Mooney Service Parts Department within 180 days of the original date (September 29, 1993) of this Service Bulletin. Normal warranty procedures on parts and kit components will be followed.

REFERENCE

DATA: N/A

PARTS LIST:

PART 1 - Kit Part Number - SB M20-255-1 (S/N 27-0002 THRU 27-0137, EXCEPT 27-0094)

Item	Part Number	Description	Quantity
1.	640130-000.	Plate, Louvered (Painted)	2
2.	640247-003.	Screen, Aluminum, (16 mesh)	2
3.	1691-0410-05	Rivet (AVEX)	26
4.	AN960-6	Washer	26
5.	640296-001.	Baffle, ABS, LH	1
6.	640296-002.	Baffle, ABS, RH	1
7.	* Paint	To match A/C color	1
8.	Compliance Card	To be returned to Service Parts	1

* **NOTE** - Matching paint will be shipped with kit. Provide aircraft S/N when ordering above kit part number.

PART 2 - Kit Part Number - SB M20-255-2 (S/N 27-0053 THRU 27-0167, EXCEPT 27-0094)

1.	640326-511.	Butterfly assembly	1
2.	MS35206-226	Screw	2
3.	Compliance Card	To be returned to Service Parts	1

FIGURES/

TABLES: See Figures SB M20-255-1, SB M20-255-2 and SB M20-255-3 on following pages.

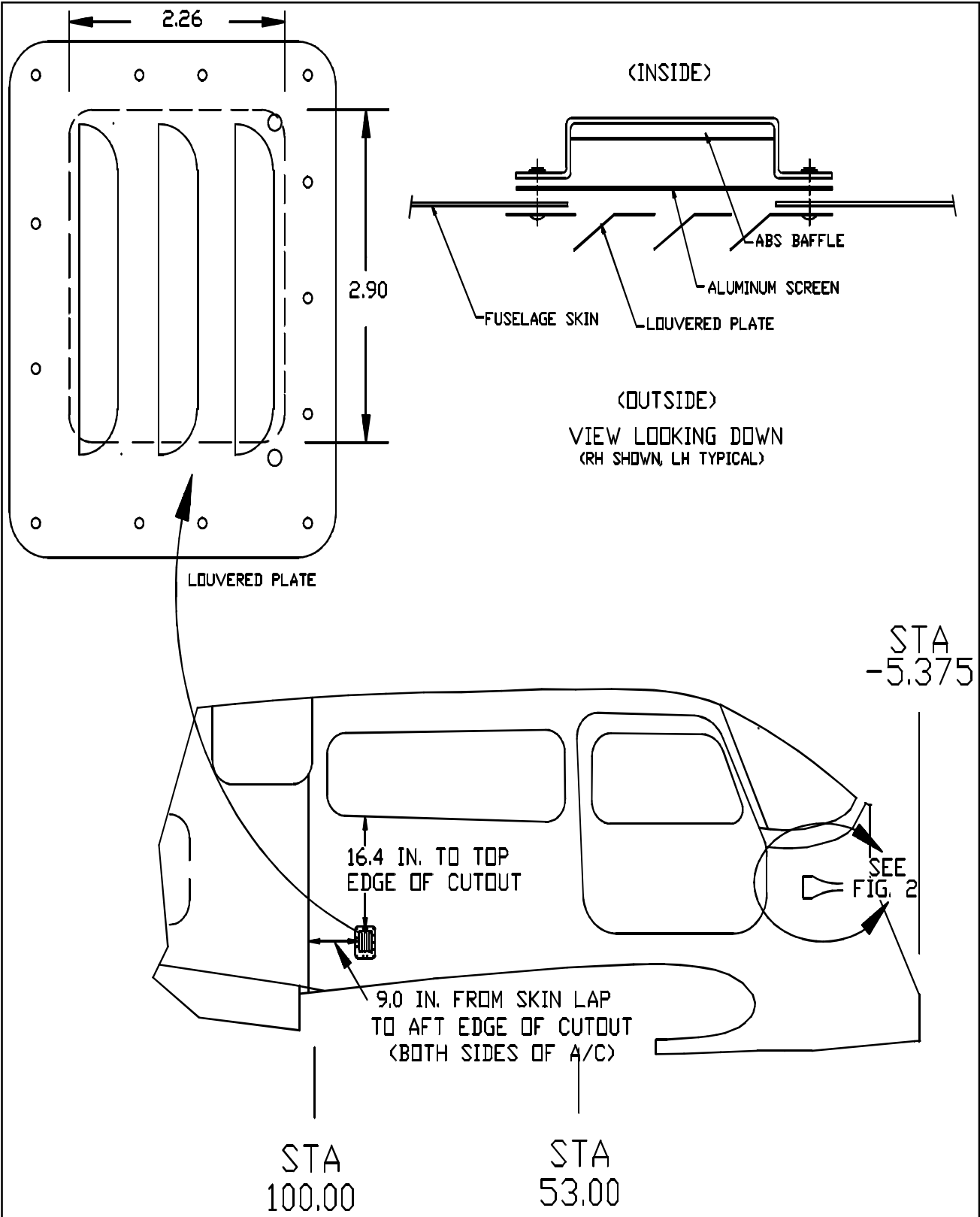

FIGURE 1

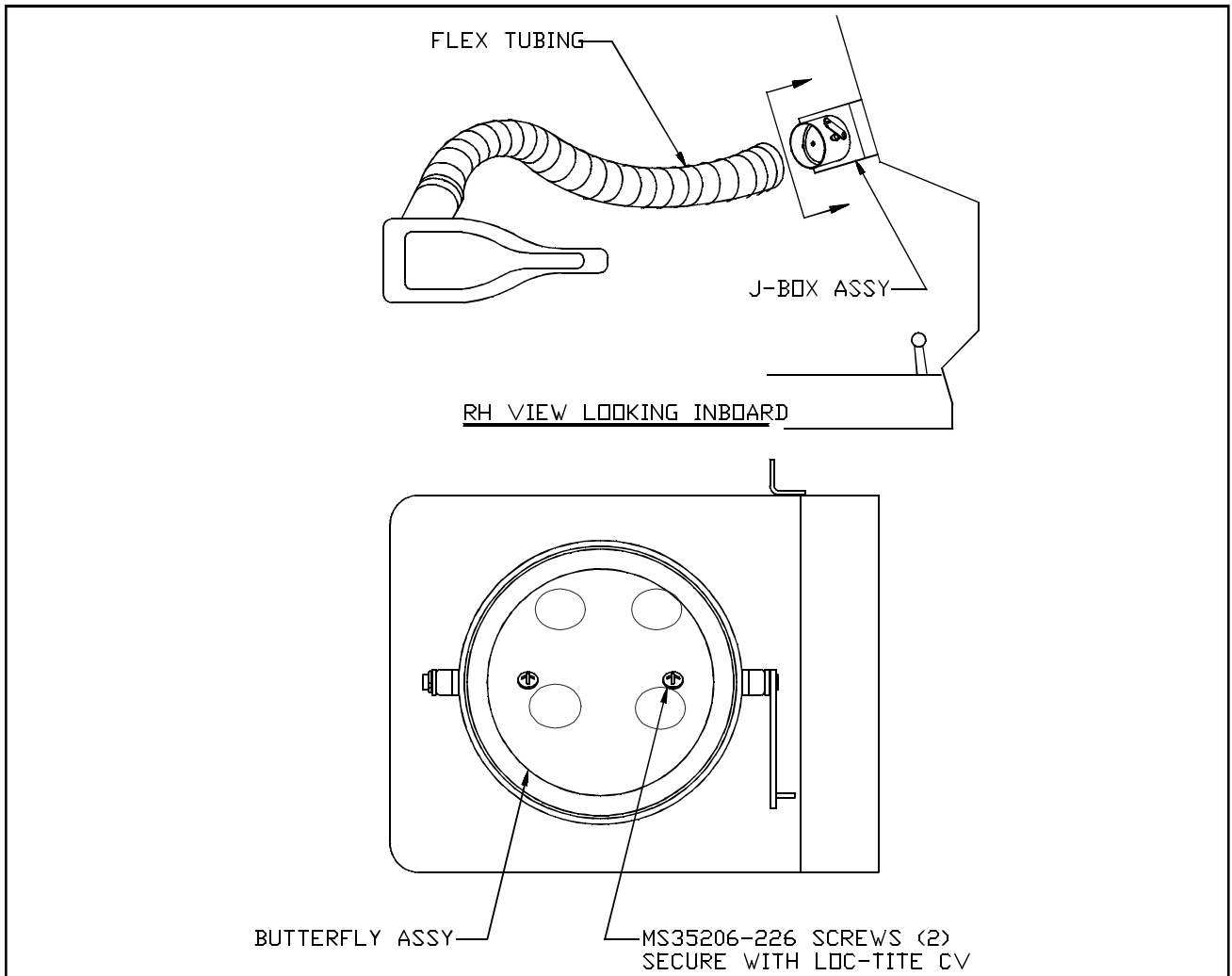

FIGURE 2

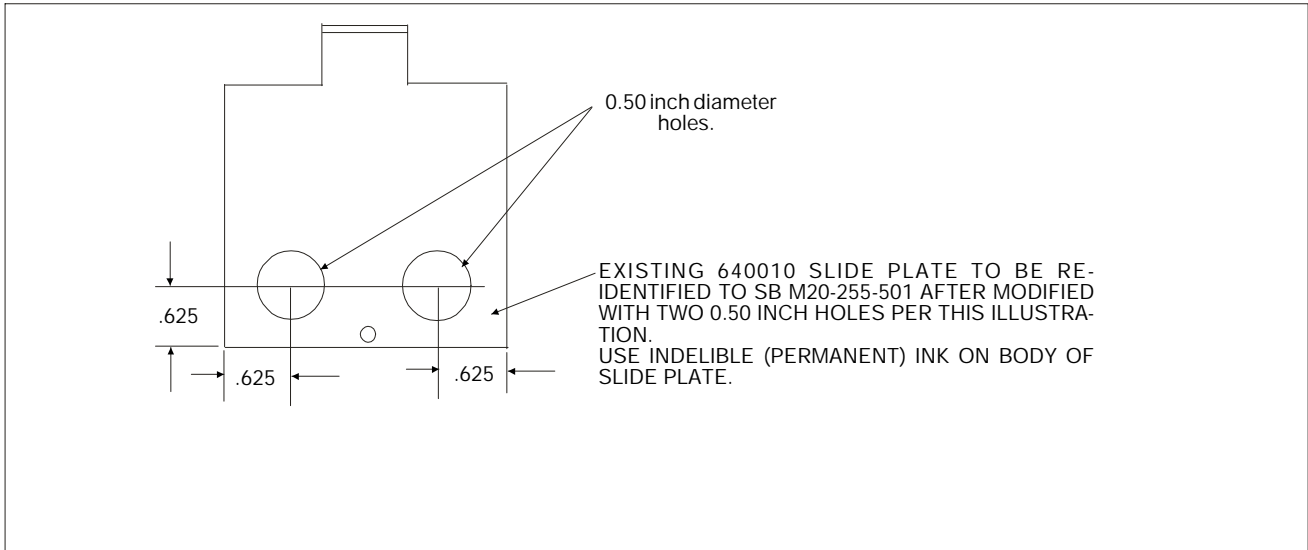

FIGURE 3