



## SERVICE BULLETIN

This Service Bulletin is FAA Approved.

SUBJECT: NOSE GEAR STEERING/TRACKING IMPROVEMENT

MODELS &  
S/N AFFECTED: All Mooney Models M20C,D,E,F,G,J Series  
aircraft up to:

M20C 20-1236  
M20D 261  
M20E 21-1181  
M20F 22-1440  
M20G 700007  
M20J 24-0263

(These aircraft and subsequent are not affected by this bulletin.)

NOTE: All aircraft manufactured after 7/6/77 have been checked prior to licensing.

TIME OF  
COMPLETION: At owner's discretion.

INTRODUCTION: The purpose of this bulletin is to provide instructions for checking the location of the nose wheel and instructions for adjustment of the nose gear assembly, if necessary, to locate the nose wheel in the position to obtain optimum tracking and nose gear steering during the high speed ground operations or take-offs and landings. It is recommended that this check and modification, if required, be accomplished especially if control difficulties have been encountered during these operations.

INSTRUCTIONS:

1. Level aircraft per Service & Maintenance Manual.
2. Center nose wheel.
3. Place plumb line over and forward of nose gear trunnion (see illustration) part number 540001-503.
4. Measure forward from aft edge of plumb line to axle center line. Modification relocating nose wheel should be accomplished if axle position, forward of plumb line, exceeds .06.

Service Bulletin Kit: M20-202-3 Spacer

MODIFICATION:

1. Add SB 20-202-3 spacer under 510027 collar.
2. Run gear through up/down cycle. Check nose gear door and wheelwell tire clearances. Re-rig gear if required.

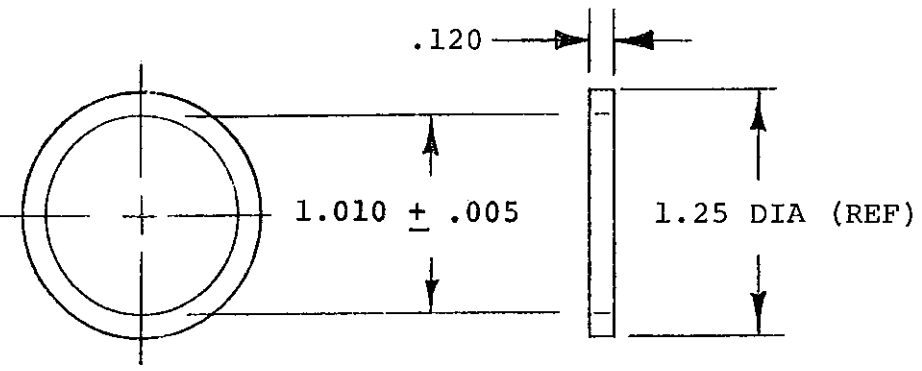

SB NO. 20-202-3 SPACER  
1-1/4" O.D. x .120 STL TUB.  
4130 COND. N  
FINISH - ZINC CHROMATE PRIMER

