

MOONEY AIRCRAFT CORPORATION  
Louis Schreiner Field  
KERRVILLE, TX. 78028

FAA APPROVED  
AIRPLANE FLIGHT MANUAL SUPPLEMENT  
FOR  
MOONEY MODEL M20M, M20R, M20S  
WITH  
KING 150 SERIES FLIGHT CONTROL SYSTEM

Reg. No. \_\_\_\_\_

Serial No. \_\_\_\_\_

The supplement must be attached to the FAA Approved Airplane Flight Manual when the King 150 Series Automatic Flight Control System is installed in accordance with Mooney drawing number 830081. The information contained herein supplements or supersedes the basic manual only in those areas listed herein. For limitations, procedures and performance information not contained in this supplement, consult the basic Airplane Flight Manual.

FAA APPROVED: Charles D. Patten

*for* Michele M. Owsley - Mgr.  
Aircraft Certification Office  
FEDERAL AVIATION ADMINISTRATION  
Fort Worth, TX  
76193-0150

DATE: 7-21-89  
Revision A 7-94  
Revision B 2-99

# MOONEY AIRCRAFT CORPORATION

LOUIS SCHREINER FIELD  
KERRVILLE, TEXAS 78028

## LOG OF REVISIONS

Revision Number	Revision Pages	Description of Revisions	FAA Approved	Date
B	Title Page, LOEP, Log of Revisions  All Pages	Added M20S application  Added M20S to Heading of all pages.	<i>Charles H. Banta</i>	2/7/99

The revised portions of affected pages are indicated by vertical black lines in the margin.

## SECTION I - GENERAL

This manual is provided to acquaint the pilot with the limitations as well as normal and emergency operating procedures of the King 150 Series Automatic Flight Control Systems. The limitations presented are pertinent to the operation of the 150 System as installed in the Mooney Model M20M, M20R, & M20S airplane; the Flight Control Systems must be operated within the limitations herein specified.

The 150 Series AFCS is certified in this airplane with 2 axis control, pitch and roll as described in Figures 1 thru 8.

The 150 Series AFCS has an electric pitch trim system which provides autotrim during autopilot operation and manual electric trim for the pilot. The trim system is designed to withstand any single inflight malfunction. Trim faults are visually and aurally annunciated.

A lockout device prevents autopilot engagement until the system has been successfully preflight tested.

The following conditions will cause the Autopilot to automatically disengage:

- A. Power failure.
- B. Internal Flight Control System failure.
- C. With the KCS 55A Compass System, a loss of compass valid (displaying HDG flag) disengages the Autopilot when a mode using heading information is engaged. With the HDG flag present, the Autopilot may be re-engaged in the basic wings level mode along with any vertical mode.
- D. Roll rates in excess of  $14^{\circ}$  per second will cause the autopilot to disengage except when the CWS switch is held depressed.
- E. Pitch rates in excess of  $5^{\circ}$  per second will cause the autopilot to disengage except when the CWS switch is held depressed.

## SECTION II - LIMITATIONS

- A. During autopilot operation, a pilot with seat belt fastened must be seated at the left pilot position.
- B. The autopilot must be OFF during takeoff and landing.
- C. The system is approved for Category I operation only (Approach mode selected).
- D. Do not operate autopilot with flaps extended beyond the take-off position.
- E. Autopilot airspeed limitations: Maximum 180 KIAS; minimum 80 KIAS.

### NOTE

**IN ACCORDANCE WITH FAA RECOMMENDATION, USE OF "ALTITUDE HOLD" MODE IS NOT RECOMMENDED DURING OPERATION IN SEVERE TURBULENCE.**

Required Placards: NONE

## SECTION III - EMERGENCY PROCEDURES

- A. In case of Autopilot malfunction: (Accomplish Items 1 and 2 simultaneously).
  - 1. Airplane Control Wheel - GRASP FIRMLY and regain aircraft control.
  - 2. A/P DISC/TRIM INTER switch - PRESS and HOLD.
  - 3. A/P DISC/TRIM INTER switch - RELEASE while observing pitch trim wheel. If pitch trim wheel is in motion, follow the Electric Trim Malfunction Procedure.
- B. In case of Electric Trim Malfunction (either manual electric or autotrim):
  - 1. A/P DISC/TRIM INTER switch - PRESS and HOLD throughout recovery.
  - 2. ELEV TRIM switch - OFF.

3. Aircraft - RETRIM manually.

**CAUTION**  
**WHEN DISCONNECTING THE AUTOPILOT AFTER A TRIM MALFUNCTION, HOLD THE CONTROL WHEEL FIRMLY; UP TO 45 POUNDS OF FORCE ON THE CONTROL WHEEL MAY BE NECESSARY TO HOLD THE AIRCRAFT LEVEL.**

Maximum Altitude losses due to autopilot malfunction:

Configuration . . . . .	Alt. Loss
Cruise, Climb, Descent . . . . .	190 FT
Maneuvering . . . . .	90 FT
APPR . . . . .	70 FT

**SECTION IV - NORMAL PROCEDURES**

A. PREFLIGHT (Perform prior to each flight)

1. GYROS - Allow 3-4 minutes for gyros to come up to speed.
2. RADIO MASTER - ON
3. ELEV TRIM - ON
4. PREFLIGHT TEST Button - PRESS momentarily and NOTE:
  - a. All annunciator lights on (TRIM annunciator flashing).
  - b. After approximately 5 seconds, all annunciator lights off, except AP, which will flash approximately 12 times and then remain off.
  - c. Note Aural Alert tone sounds with the flashing AP light.

**NOTE**  
**IF TRIM WARNING LIGHT STAYS ON THEN THE AUTOTRIM DID NOT PASS PREFLIGHT TEST. THE AUTOPILOT CIRCUIT BREAKER SHOULD BE PULLED.**  
**(THE AUTOPILOT AND MANUAL ELECTRIC TRIM WILL BE INOPERATIVE).**

5. MANUAL ELECTRIC TRIM - TEST as follows:
  - a. Actuate left side of split switch unit to the fore and aft positions. The trim wheel should not move on its own. Rotate the trim wheel manually against the engaged clutch to check the pilot's trim overpower capability.
  - b. Actuate right side of split switch unit to the fore and aft positions. Trim wheel should not move on its own and normal trim wheel force is required to move it manually.
  - c. Press the A/P DISC/TRIM INTER switch down and hold. Manual Electric Trim should not operate either nose up or nose down.
6. FLIGHT DIRECTOR (KFC 150 Only) - ENGAGE by pressing FD or CWS button.
7. AP ENG Button - PRESS to engage autopilot.
8. Flight Controls - MOVE fore, aft, left and right to verify that the autopilot can be overpowered.
9. A/P DISC/TRIM INTER switch - PRESS. Verify that the autopilot disconnects and all flight director modes are canceled.
10. TRIM - SET to take off position.

B. AUTOPILOT OPERATION

1. Before takeoff
  - A/P DISC/TRIM INTER switch - PRESS.
2. Inflight Autopilot Engagement

- a. FD Mode Selector Button (KFC 150 Only) - PRESS.
- b. AP ENG Button - PRESS. Note AP annunciator on. If no other modes are selected the autopilot will operate in wings level and pitch attitude hold.

**CAUTION**

**DO NOT HELP THE AUTOPILOT AS THE AUTOPILOT WILL RUN THE PITCH TRIM TO OPPOSE YOUR HELP.**

3. Climb or Descent

a. Using CWS

- 1) CWS Button - PRESS and Move aircraft nose to the desired attitude.
- 2) CWS Button - RELEASE. Autopilot will maintain aircraft pitch attitude up to the pitch limits of +15 or -10 .

b. Using Vertical Trim.

- 1) VERTICAL TRIM Control - PRESS either up or down to modify aircraft attitude at a rate of .7 deg/sec. up to the pitch limits of +15<sup>o</sup> or -10<sup>o</sup> .
- 2) VERTICAL TRIM Control - RELEASE when desired aircraft attitude is reached. The autopilot will maintain the desired pitch attitude.

4. Altitude Hold

a. ALT Mode Selector Button - PRESS. Note ALT mode annunciator ON. Autopilot will maintain the selected pressure altitude.

b. Change selected altitudes

- 1) Using CWS (recommended for altitude changes greater than 100 ft.).
  - a) CWS Button - PRESS and fly aircraft to desired pressure altitude.
  - b) CWS Button - RELEASE when desired pressure altitude is reached. The autopilot will maintain the desired pressure altitude.
- 2) Using Vertical Trim (Recommended for altitude changes less than 100 ft.)
  - a) VERTICAL TRIM Control - PRESS either up or down. Vertical Trim will seek an altitude rate of change of about 500 fpm
  - b) VERTICAL TRIM Control - RELEASE when desired pressure altitude is reached. The autopilot will maintain the desired pressure altitude.

5. Heading Changes

a. Manual Heading Changes.

- 1) CWS Button - PRESS and MANEUVER aircraft to the desired heading.
- 2) CWS Button - RELEASE. Autopilot will maintain aircraft in wings level attitude.

**NOTE**

**AIRCRAFT HEADING MAY CHANGE IN THE WINGS LEVEL MODE DUE TO AN AIRCRAFT OUT OF TRIM CONDITION.**

b. Heading Hold

- 1) HEADING Selector Knob - SET BUG to desired heading.
- 2) HDG Mode Selector Button - PRESS. Note HDG mode annunciator ON. Autopilot will automatically turn the aircraft to the selected heading.

c. Command Turns (Heading Hold mode ON)

- 1) HEADING Selector Knob -MOVE BUG to the desired heading. Autopilot will automatically turn the aircraft to the new selected heading.

6. NAV Coupling

a. When equipped with HSI.

- 1) Course Bearing Pointer - SET to desired course.

**NOTE**

**WHEN EQUIPPED WITH NAV 1/NAV 2 SWITCHING AND NAV 2 IS SELECTED,  
SET OBS TO THE DESIRED COURSE.**

2) HEADING Selector Knob - SET BUG to provide desired intercept angle.

3) NAV Mode Selector Button - PRESS.

a) If the Course Deviation Bar is greater than 2 to 3 dots: the aircraft will continue in HDG mode (or wings level if HDG not selected) with the NAV annunciator flashing; when the computed capture point is reached the HDG will disengage, the NAV annunciator will illuminate steady and the selected course will be automatically captured and tracked.

b) If the D-Bar is less than 2 to 3 dots: the HDG mode will disengage upon selecting NAV mode; the NAV annunciator will illuminate steady and the capture/track sequence will automatically begin.

b. When equipped with DG.

1) OBS Knob - SELECT desired course.

2) NAV Mode Selector Button - PRESS.

3) HEADING Selector Knob - ROTATE BUG to agree with OBS course.

**NOTE**

**WHEN NAV IS SELECTED, THE LATERAL OPERATING MODE WILL CHANGE  
FROM HDG (IF SELECTED) TO WINGS LEVEL FOR 5 SECONDS. A 45°  
INTERCEPT ANGLE WILL THEN BE AUTOMATICALLY ESTABLISHED  
BASED ON THE POSITION OF THE BUG.**

a) If the D-Bar is greater than 2 to 3 dots: the autopilot will annunciate HDG mode (unless HDG not selected) and NAV flashing; when the computed capture point is reached the HDG annunciator will go out, the NAV annunciator will illuminate steady and the selected course will be automatically captured and tracked.

b) If the D-Bar is less than 2 to 3 dots: the HDG mode will disengage upon selecting NAV mode; the NAV annunciator will illuminate steady and the capture/track sequence will automatically begin.

7. Approach (APR) Coupling.

a. When equipped with HSI.

1) COURSE Bearing Pointer - SET to desired course.

**NOTE**

**WHEN EQUIPPED WITH NAV 1/NAV 2 SWITCHING AND NAV 2 IS SELECTED,  
SET OBS TO THE DESIRED COURSE.**

2) HEADING Selector Knob - SET BUG to provide desired intercept angle.

3) APR Mode Selector Button - PRESS.

a) If the Course Deviation Bar is greater than 2 to 3 dots: the aircraft will continue in HDG mode (or wings level if HDG not selected) with the APR annunciator flashing; when the computed capture point is reached the HDG will disengage, the APR annunciator will illuminate steady and the selected course will be automatically captured and tracked.

b) If the D-Bar is less than 2 to 3 dots: the HDG mode will disengage upon selecting APR mode; the APR annunciator will illuminate steady and the capture/track sequence will automatically begin.

c) When equipped with DG.

1) OBS Knob - SELECT desired approach course.

2) APR Mode Selector Button - PRESS.

3) HEADING Selector Knob - ROTATE Bug to agree with OBS course.

**NOTE**

**WHEN APR IS SELECTED, THE LATERAL OPERATING MODE WILL CHANGE FROM HDG (IF SELECTED) TO WINGS LEVEL FOR 5 SECONDS. A 45° INTERCEPT ANGLE WILL THEN BE AUTOMATICALLY ESTABLISHED BASED ON THE POSITION OF THE BUG.**

a) If the D-Bar is greater than 2 to 3 dots: the autopilot will annunciate HDG mode (unless HDG not selected) and APR flashing; when the computed capture point is reached the HDG annunciator will go out, the APR annunciator will illuminate steady and the selected course will be automatically captured and tracked.

b) If the D-Bar is less than 2 to 3 dots: the HDG mode will disengage upon selecting APR mode; the APR annunciator will illuminate steady and the capture/track sequence will automatically begin.

8. BC Approach Coupling.

a. When equipped with HSI.

- 1) COURSE Bearing Pointer - SET to the ILS front course inbound heading.

**NOTE**

**WHEN EQUIPPED WITH NAV 1/NAV 2 SWITCHING AND NAV 2 IS SELECTED, SET OBS TO THE ILS FRONT COURSE INBOUND HEADING.**

- 2) HEADING Selector Knob - SET BUG to provide desired intercept angle.

- 3) BC Mode Selector Button - PRESS.

a) If the Course Deviation Bar is greater than 2 to 3 dots: the aircraft will continue in HDG mode (or wings level if HDG not selected) with BC annunciated steady and APR annunciator flashing; when the computed capture point is reached the HDG will disengage, and the BC and APR annunciators will illuminate steady and the selected course will be automatically captured and tracked.

b) If the D-Bar is less than 2 to 3 dots: the HDG mode will disengage upon selecting BC mode; the APR BC annunciator will illuminate steady and the capture/track sequence will automatically begin.

b. When equipped with DG.

- 1) OBS Knob - SELECT the ILS front course inbound heading.
- 2) BC Mode Selector button - PRESS.
- 3) HEADING Selector Knob - ROTATE Bug to the ILS front course inbound heading.

**NOTE**

**WHEN BC IS SELECTED, THE LATERAL OPERATING MODE WILL CHANGE FROM HDG (IF SELECTED) TO WINGS LEVEL FOR 5 SECONDS. A 45° INTERCEPT ANGLE WILL THEN BE ESTABLISHED BASED ON THE POSITION OF THE BUG.**

a) If the D-Bar is greater than 2 to 3 dots: the autopilot will annunciate HDG (unless HDG not selected) and BC modes with APR flashing; when the computed capture point is reached the HDG annunciator will go out, the BC and APR annunciators will illuminate steady and the selected course will be automatically captured tracked.

b) If the D-Bar is less than 2 to 3 dots: the HDG mode will disengage upon selecting BC mode; the BC and APR annunciators will illuminate steady and the capture/track sequence will automatically begin.

9. Glideslope Coupling.

**NOTE**

**GLIDESLOPE COUPLING IS INHIBITED WHEN OPERATING IN NAV OR APR BC MODES. GLIDESLOPE COUPLING OCCURS AUTOMATICALLY IN THE APR MODE.**

a. APR Mode - ENGAGED.

b. At glideslope centering - NOTE GS annunciator ON.

**NOTE**  
**AUTOPILOT CAN CAPTURE GLIDESLOPE FROM ABOVE OR BELOW THE BEAM WHILE OPERATING IN EITHER PITCH ATTITUDE HOLD OR ALT HOLD MODES.**

10. Missed Approach.

- a. A/P DISC/TRIM INTER switch - PRESS to disengage AP.
- b. MISSED APPROACH - EXECUTE.
- c. CWS Button - PRESS (KFC 150 ONLY) as desired to activate FD mode during Go-Around maneuver.
- d. AP ENG Button - PRESS (if AP operation is desired). Note AP annunciator ON.

**NOTE**  
**IF IT IS DESIRED TO TRACK THE ILS COURSE OUTBOUND AS PART OF THE MISSED APPROACH PROCEDURE, USE THE NAV MODE TO PREVENT INADVERTENT GS COUPLING.**

11. Before Landing.

A/P DISC/TRIM INTER switch - PRESS to disengage AP.

C. FLIGHT DIRECTOR OPERATION (KFC 150 Systems Only).

**NOTE**  
**THE FLIGHT DIRECTOR MODES OF OPERATION ARE THE SAME AS THOSE USED FOR AUTOPILOT OPERATIONS EXCEPT THE AUTOPILOT IS NOT ENGAGED AND THE PILOT MUST MANEUVER THE AIRCRAFT TO SATISFY THE FLIGHT DIRECTOR COMMANDS.**

**SECTION V thru VI**

No Change.

**SECTION VII - SYSTEM DESCRIPTIONS**

1. KFC 150 SYSTEM KC 192 AUTOPILOT COMPUTER - Complete Flight Director and Autopilot computer, including system mode annunciators and system controls.

2. (Not used)

3. MODE ANNUNCIATORS - Illuminate when a mode is selected by the corresponding mode selector button (PUSH ON - PUSH OFF).

4. GLIDESLOPE (GS) ANNUNCIATOR - Illuminates continuously whenever the autopilot is coupled to the glideslope signal. The GS annunciator will flash if the glideslope signal is lost. (GS flag in CDI or absence of glideslope pointers in KI 525A). The autopilot reverts to pitch attitude hold operation. If a valid glideslope signal returns within six seconds, the autopilot will automatically recouple in the GS mode. If the valid signal does not return within six seconds, the autopilot will remain in pitch attitude hold mode until such time that a valid glideslope returns and the aircraft passes thru the glideslope. At that point GS couple will re-occur.

5. TRIM WARNING LIGHT (TRIM) - Illuminates continuously whenever trim power is not on or the system has not been preflight tested. The TRIM warning light illuminates and is accompanied by an audible warning whenever a manual trim fault is detected. The Manual Trim System is monitored for the Trim Servo running without a command. The TRIM warning light will illuminate and be accompanied by an audible warning whenever an autotrim failure occurs. The autotrim system is monitored for the following failures: trim servo running without a command; trim servo not running when commanded to run; trim servo running in the wrong direction.

6. AUTOPILOT (AP) ANNUNCIATOR - Illuminates continuously whenever the autopilot is engaged. Flashes approximately 12 times whenever the autopilot is disengaged (an aural alert will also sound for 2 seconds).

7. AUTOPILOT ENGAGE (AP ENG) BUTTON - When pushed, engages autopilot if all logic conditions are met. When pushed again, disengages autopilot.



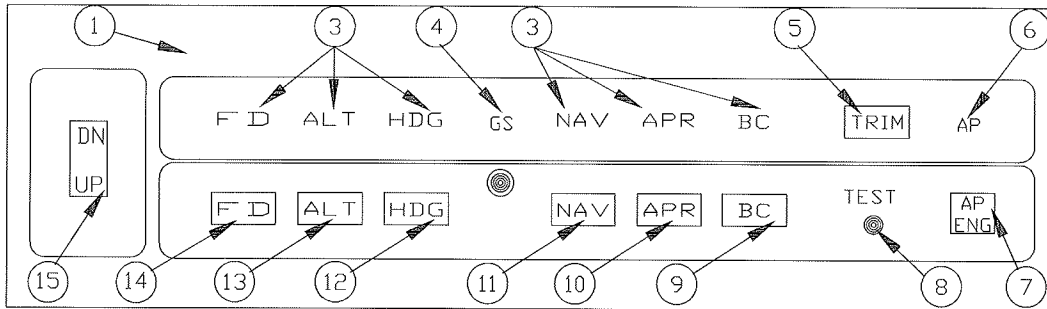

FIGURE 1 - KC 192 AUTOPILOT & FLIGHT DIRECTOR COMPUTER

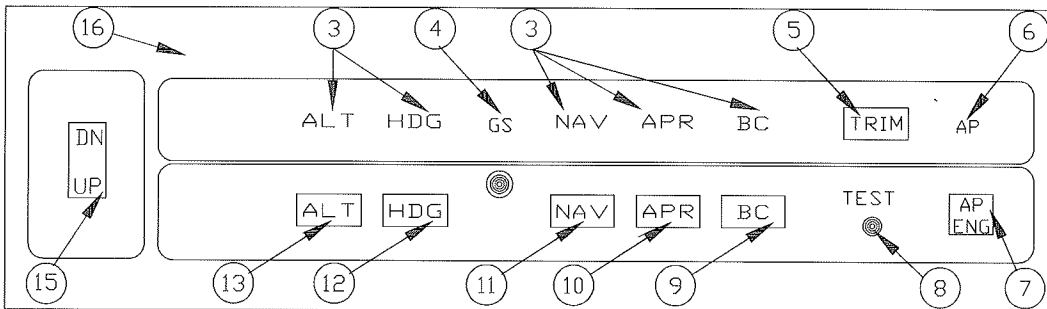

FIGURE 2 - KC 191 AUTOPILOT COMPUTER

**8. PREFLIGHT TEST (TEST) BUTTON** - When momentarily pushed, initiates preflight test sequence which automatically turns on all annunciator lights, tests the roll and pitch rate monitors, tests the autotrim fault monitor, checks the manual trim drive voltage and tests all autopilot valid and dump logic. If the preflight is successfully passed, the AP annunciator light will flash for approximately 6 seconds (an aural tone will also sound simultaneously with the annunciator flashes). The autopilot cannot be engaged until the autopilot preflight tests are successfully passed.

**9. BACK COURSE APPROACH (BC) MODE SELECTOR BUTTON** - When pushed will select the Back Course Approach mode. This mode functions identically to the approach mode except that response to LOC signals is reversed. Glideslope coupling is inhibited in the Back Course Approach mode.

**10. APPROACH (APR) MODE SELECTOR BUTTON** - When pushed, will select the Approach mode. This mode provides all angle intercept (with HSI) or a fixed angle intercept of 45° (with DG), automatic beam capture and tracking of VOR, RNAV or LOC signals plus Glideslope coupling in the case of an ILS. The tracking gain of the APR mode is greater than the gain in the NAV mode. The APR annunciator on the Autopilot Computer will flash until the automatic capture sequence is initiated. At beam capture, APR will annunciate without flashing.

**11. NAVIGATION (NAV) MODE SELECTOR BUTTON** - When pushed will select the Navigation mode. The mode provides all angle intercept (with HSI) or a fixed angle intercept of 45° (with DG), automatic beam capture and tracking of VOR, RNAV or LOC signals. The NAV annunciator on the Autopilot Computer will flash until the automatic capture sequence is initiated. At beam capture, NAV will annunciate without flashing.

**12. HEADING (HDG) MODE SELECTOR BUTTON** - When pushed will select the Heading mode, which commands the airplane to turn to and maintain the heading selected by the heading bug on the DG or HSI. A new heading may be selected at any time and will result in the airplane turning to the new heading with a maximum bank angle of about 22°. Selecting HDG mode will cancel NAV, APR or BC track modes.

**13. ALTITUDE HOLD (ALT) MODE SELECTOR BUTTON** - When pushed will select the Altitude Hold mode, which commands the airplane to maintain the pressure altitude existing at the moment of selection. Engagement may be accomplished in climb, descent, or level flight. In the APR mode, altitude hold will automatically disengage when the glideslope is captured.

14. FLIGHT DIRECTOR (FD) MODE SELECTOR BUTTON - When pushed will select the Flight Director mode (with KC 192 Autopilot Computer only), bringing the Command Bar in view on the KI 256 and will command wings level and pitch attitude hold. The FD mode must be selected prior to Autopilot engagement.

15. VERTICAL TRIM CONTROL - A spring loaded to center rocker switch which will provide up or down pitch command changes: while in ALT will adjust altitude at rate of about 500 fpm; when not in ALT will adjust pitch attitude at a rate of .7 deg/sec. Will cancel GS couple. The aircraft must pass through the glideslope again to allow GS recouple.

16. KAP 150 SYSTEM KC 191 AUTOPILOT COMPUTER - Complete Autopilot computer, including system mode annunciators and system controls.

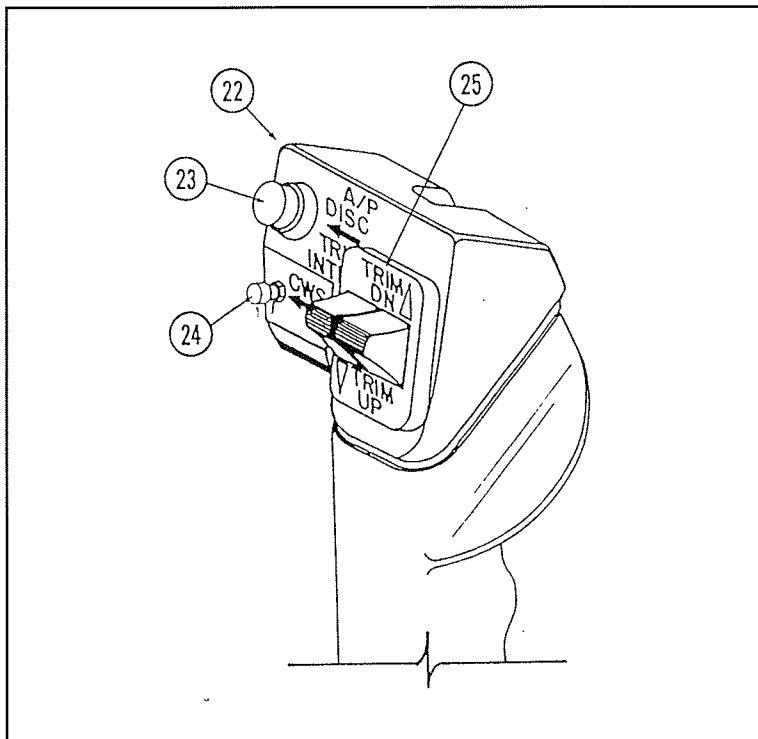

FIGURE 3 - A/P CONTROL WHEEL SWITCH CAP

17. thru 21. (Not used)

22. AUTOPILOT CONTROL WHEEL SWITCH CAP - Switch assembly mounted on the pilot's control wheel associated with the autopilot and manual electric trim systems.

23. AUTOPILOT DISCONNECT/TRIM INTERRUPT (A/P DISC/TRIM INTER) Switch - When depressed will disengage the autopilot and cancel all operating Flight Director modes. When depressed and held will interrupt all electric trim power (stop trim motion), disengage the autopilot and cancel all operating Flight Director modes.

24. CONTROL WHEEL STEERING (CWS) BUTTON - When depressed, allows pilot to manually

control the aircraft (disengages the pitch and roll servos) without cancellation of any of the selected modes. Will engage the Flight Director mode if not previously engaged. Automatically synchronizes the Flight Director/Autopilot to the pitch attitude present when the CWS switch is released, or to the present pressure altitude when operating in the ALT hold mode. Will cancel GS couple. The aircraft must pass through the glideslope again to allow GS recouple.

25. MANUAL ELECTRIC TRIM CONTROL SWITCHES - A split switch unit in which the left half provides power to engage the trim servo clutch and the right half to control the direction of motion of the trim servo motor. Both halves of the split trim switch must be actuated in order for the manual trim to operate in the desired direction. When the autopilot is engaged, operation of the manual electric trim will automatically disconnect the autopilot.

26. KI 256 FLIGHT COMMAND INDICATOR (FCI) - Displays airplane attitude as a conventional attitude gyro and displays commands for flight director operation. The gyro is air driven.

27. DECISION HEIGHT (DH) ANNUNCIATOR LIGHT - Optional light for use with the aircraft's optional radar altimeter.

28. ROLL ATTITUDE INDEX - Displays airplane roll attitude with respect to the roll attitude scale.

29. ROLL ATTITUDE SCALE - Scale marked at 0, +/-10, 20, 30, 60, and 90°.

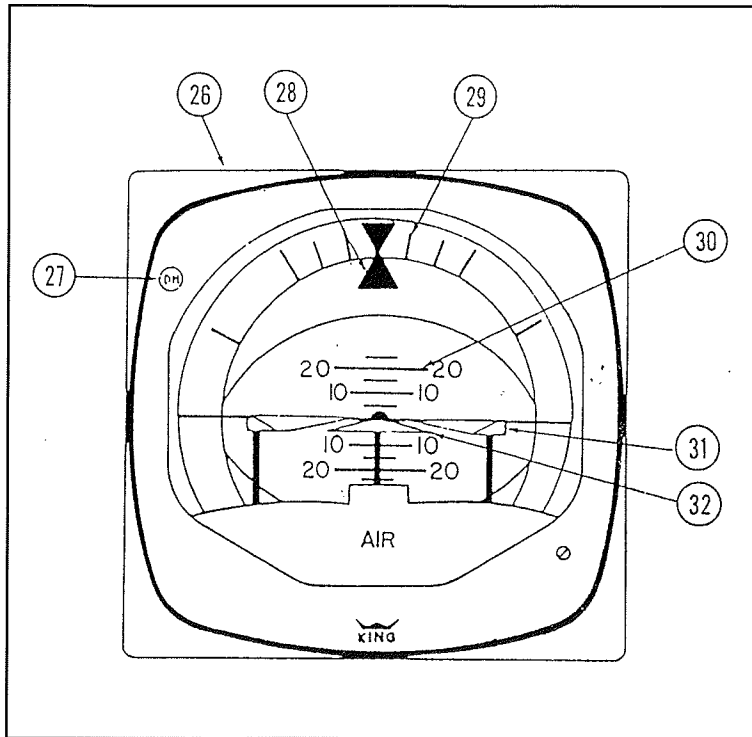

FIGURE 4 - KI 256 FLIGHT COMMAND INDICATOR

30. PITCH ATTITUDE SCALE - Moves with respect to the symbolic airplane to present pitch attitude. Scale graduated at 0, +/-5, 10, 15, 20 and 25°.

31. COMMAND BAR - Displays computed steering commands referenced to the symbolic airplane. The command bar is visible only when FD mode is selected. The command bar will be biased out of view whenever the system is invalid or a Flight Director mode is not engaged.

32. FCI SYMBOLIC AIRPLANE - Airplane pitch and roll attitude is displayed by the relationship between the fixed symbolic airplane and the movable background. During flight director operation, the symbolic airplane is

flown to align it with the command bar to satisfy the flight director commands.

33. KG 258 VERTICAL GYRO - Displays airplane attitude as a conventional attitude gyro. The gyro is air driven.

34. SYMBOLIC AIRPLANE - Serves as a stationary symbol of the aircraft. Aircraft pitch and roll attitudes are displayed by the relationship between the fixed symbolic aircraft and the movable background.

35. SYMBOLIC AIRCRAFT ALIGNMENT KNOB - Provides manual positioning of the symbolic aircraft for level flight under various load conditions.

36. KI 525A HORIZONTAL SITUATION INDICATOR (HSI) - Provides a pictorial presentation of aircraft deviation relative to VOR radials or localizer beams. It also displays glideslope deviations and gives heading reference with respect to magnetic north.

37. NAV FLAG - Flag is in view when the NAV receiver signal is inadequate. When a NAV flag is present in the navigation indicator (CDI or KI 525A) the autopilot operation is not affected. The pilot must monitor the navigation indicators for NAV

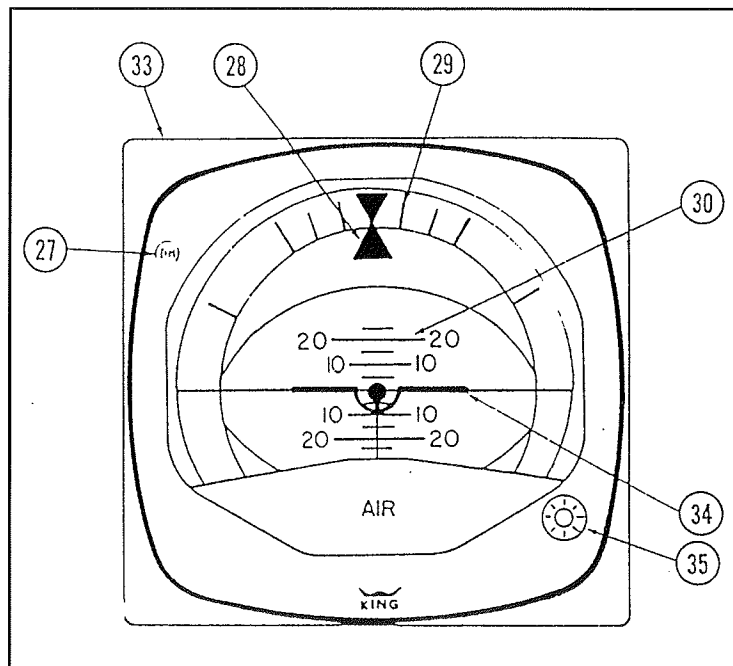

FIGURE 5 - KG 258 VERTICAL GYRO

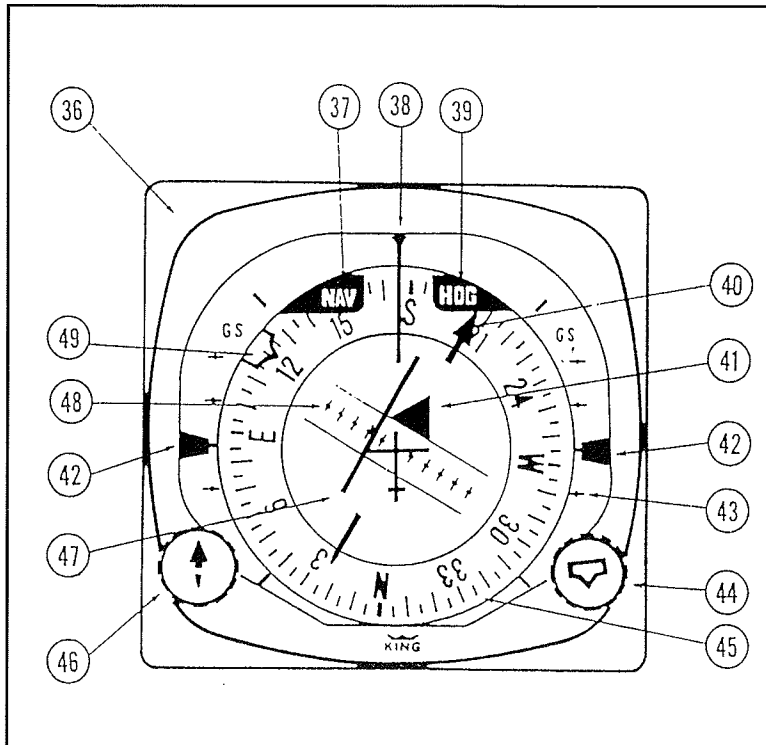

FIGURE 6 - KI 525A HSI

flags to insure that the Autopilot and/or Flight Director and tracking valid navigation information.

38. LUBBER LINE - Indicates aircraft magnetic heading on compass card (45).

39. HEADING WARNING FLAG (HDG) - When flag is in view the heading display is invalid. If a HDG flag appears and a lateral mode (HDG, NAV, APR or APR BC) is selected, the Autopilot will be disengaged. The Autopilot may be re-engaged in the basic wings level mode along with any vertical mode. The CWS switch would be used to manually maneuver the aircraft laterally.

40. COURSE BEARING POINTER - Indicates selected VOR course or localizer

course on compass card (45). The selected VOR radial or localizer heading remains set on the compass card when the compass card (45) rotates.

41. TO/FROM INDICATOR FLAG - Indicates direction of VOR station relative to selected course.

42. DUAL GLIDESLOPE POINTERS - Indicate on glideslope scale (43) aircraft displacement from glideslope beam center. Glideslope pointers in view indicate a usable glideslope signal is being received.

43. GLIDESLOPE SCALES - Indicate displacement from glideslope beam center. A glideslope deviation bar displacement of 2 dots, represents full scale (0.7°) deviation above or below glideslope beam centerline.

44. HEADING SELECTOR KNOB  - Positions heading bug (49) on compass card (45) by rotating the heading selector knob. The Bug rotates with the compass card.

45. COMPASS CARD - Rotates to display heading of airplane with reference to lubber line (38) on HSI or DG.

46. COURSE SELECTOR KNOB - Positions course bearing pointer (40) on the compass card (45) by rotating the course selector knob.

47. COURSE DEVIATION BAR (D-BAR) - The center portion of omni bearing pointer moves laterally to pictorially indicate the relationship of aircraft to the selected course. It indicates degrees of angular displacement from VOR radials and localizer beams, or displacement in nautical miles from RNAV courses.

48. COURSE DEVIATION SCALE - A course deviation bar displacement of 5 dots represents full scale (VOR = +/-10, LOC = +/-2 1/2, RNAV = 5NM, RNAV APR = 1 1/4NM) deviation from beam centerline.

49. HEADING BUG - Moved by  knob (44) to select desired heading.

50. KG 107 NON-SLAVED DIRECTIONAL GYRO (DG) - Provides a stable visual indication of aircraft heading to the pilot. The gyro is air driven.

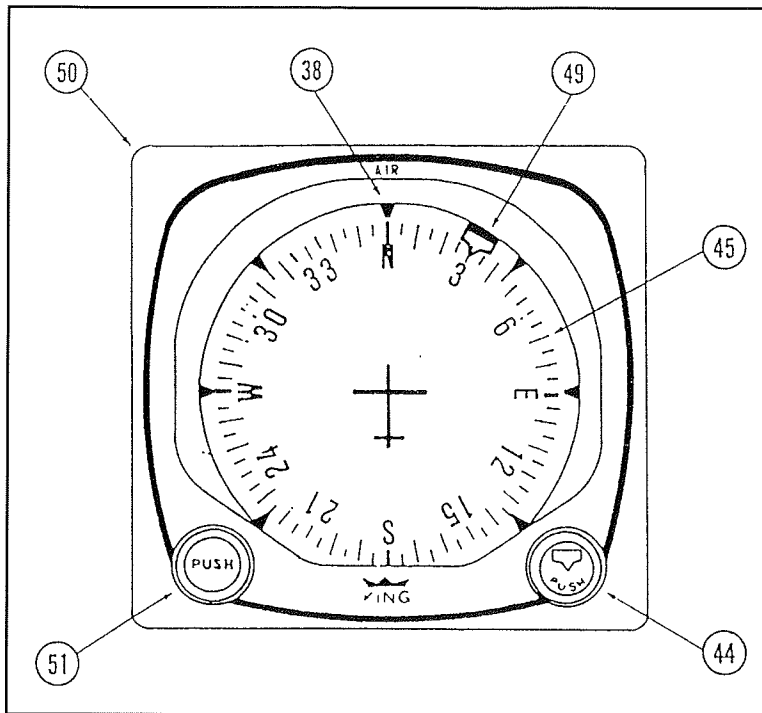

FIGURE 7 - KG 107 DG

51. GYRO ADJUSTMENT KNOB (PUSH) - When pushed in, allows the pilot to manually rotate the gyro compass card (45) to correspond with the magnetic heading indicated by the magnetic compass. The unslaved compass card must be manually reset periodically to compensate for precessional errors in the gyro.

52. KI 204/206 VOR/LOC/GLIDESLOPE INDICATOR - Provides rectilinear display of VOR/LOC and Glideslope deviation.

53. COURSE INDEX - Indicates selected VOR course.

54. COURSE CARD - Indicates selected VOR course under course index.

55. GLIDESLOPE DEVIATION NEEDLE - Indicates deviation from ILS glideslope.

56. GLIDESLOPE SCALE - Indicates displacement from glideslope beam center. A glideslope deviation needle displacement of 5 dots, represents full scale ( $0.7^\circ$ ) deviation above or below glideslope beam centerline.

57. RECIPROCAL COURSE INDEX - Indicates reciprocal of selected VOR course.

58. OMNI BEARING SELECTOR (OBS) KNOB - Rotates course card to selected course.

59. COURSE DEVIATION NEEDLE - Indicates course deviation from selected omni course or localizer centerline.

60. GLIDESLOPE (GS) FLAG - Flag is in view when the GS receiver signal is inadequate.

The airplane MASTER SWITCH function is unchanged and can be used in an emergency to shut off electrical power to all flight control systems while the problem is being isolated.

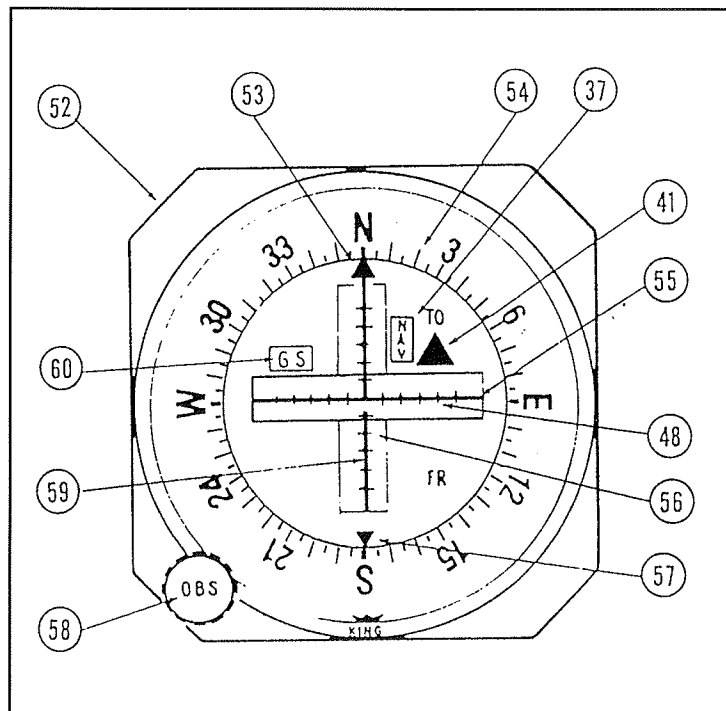

FIGURE 8 - KI 204/206 VOR/LOC/GS INDICATOR

The RADIO MASTER switch supplies power to the avionics bus bar of the radio circuit breakers and the autopilot circuit breaker.

The following circuit breakers are used to protect the following elements of the King 150 Series Autopilot:

LABEL	FUNCTION
AUTOPILOT/TRIM . . . . .	Supplies power to the KC 192 or the KC 191 Computer, the autopilot pitch and roll servos, and the Elev Trim Switch/Circuit Breaker.
RADIO MASTER . . . . .	Switch /circuit breaker supplies power to the avionics bus.
ELEV TRIM . . . . .	Switch/circuit breaker supplies power to the autotrim and manual electric pitch trim systems.
HSI . . . . .	Supplies power to the optional KCS 55A Compass System.
AUTOPILOT/ALERT . . . . .	Supplies power to the KAA 15 Aural Alert Box.

**SECTION VIII THRU X**

No Change.